

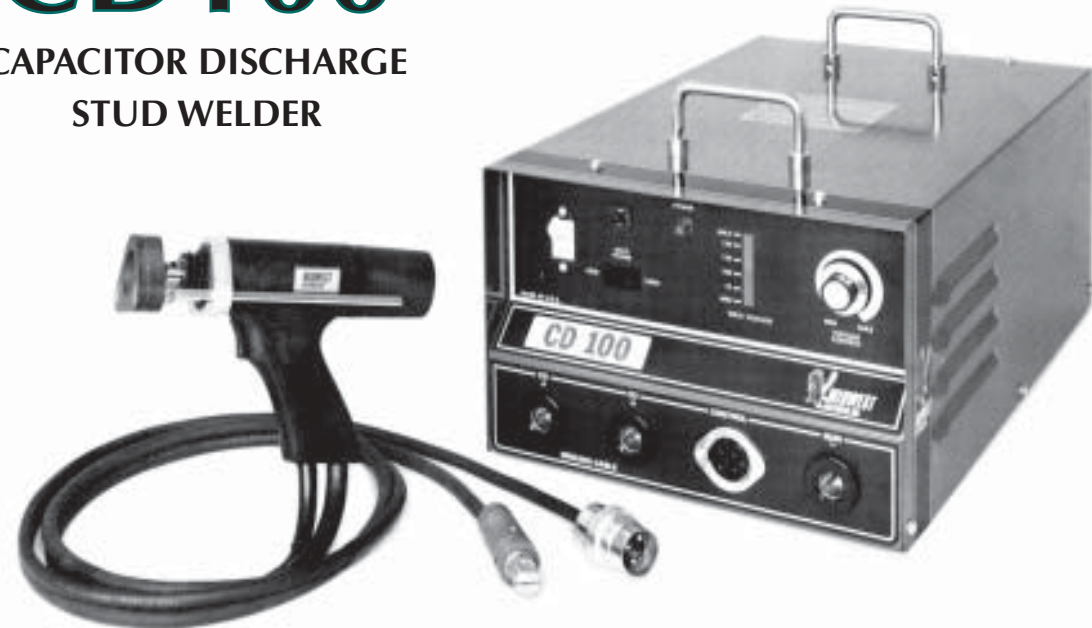

MIDWEST Fasteners, Inc.
 450 Richard St. • Miamisburg, OH 45342
 www.midwestfasteners.com • email: sales@midwestfasteners.com
 Toll Free: 800/852-8352 • Fax: 937/866-4174

CD100

CAPACITOR DISCHARGE STUD WELDER



The **CD100 Capacitor Discharge Stud Welder** from Midwest Fasteners is one of the most powerful units on the market today. With solid state design, the CD100 is perfectly matched to heavy-duty industrial fastening for welding larger diameter CD studs.

Not only can the CD100 weld materials such as mild steel, stainless steel, aluminum and brass—the unit is also capable of welding studs up to 3/8" diameter weld base. Due to the speedy capacitor discharge process, studs can be welded to materials as thin as .020" gauge without burning through.

The CD100 comes equipped with a *high/low power range switch* that is helpful in welding small and large diameter fasteners. This variable capacitance switch allows the operator to fine tune critical applications from 84,000 to 168,000 MFD. Another unique feature of the CD100 is the *LED panel meter*, which displays capacitor discharge voltage at a glance.

Solid state circuitry and rugged steel chassis assure durability and long service life. What's more, the unit is loaded with safety features. *Circuit breaker protection* prevents expensive repair to component parts, such as printed circuit board. The *recessed control panel* protects gauges and control knobs. And the *auto fault shut off* aids in operator safety.

An *ultra-light 24 ounce "Precision Contact Gun"* is included with the CD100 welding system. With this gun, operator fatigue is reduced – thereby increasing production. The CD100 contact gun also includes *interchangeable main spring pressure* that is necessary for many special welding applications, and critical in welding aluminum fasteners and dissimilar materials.

The CD100. Available only from Midwest Fasteners – your complete source for stud welded fasteners and CD stud welding systems.

CD100 CAPACITOR DISCHARGE WELDING SYSTEM

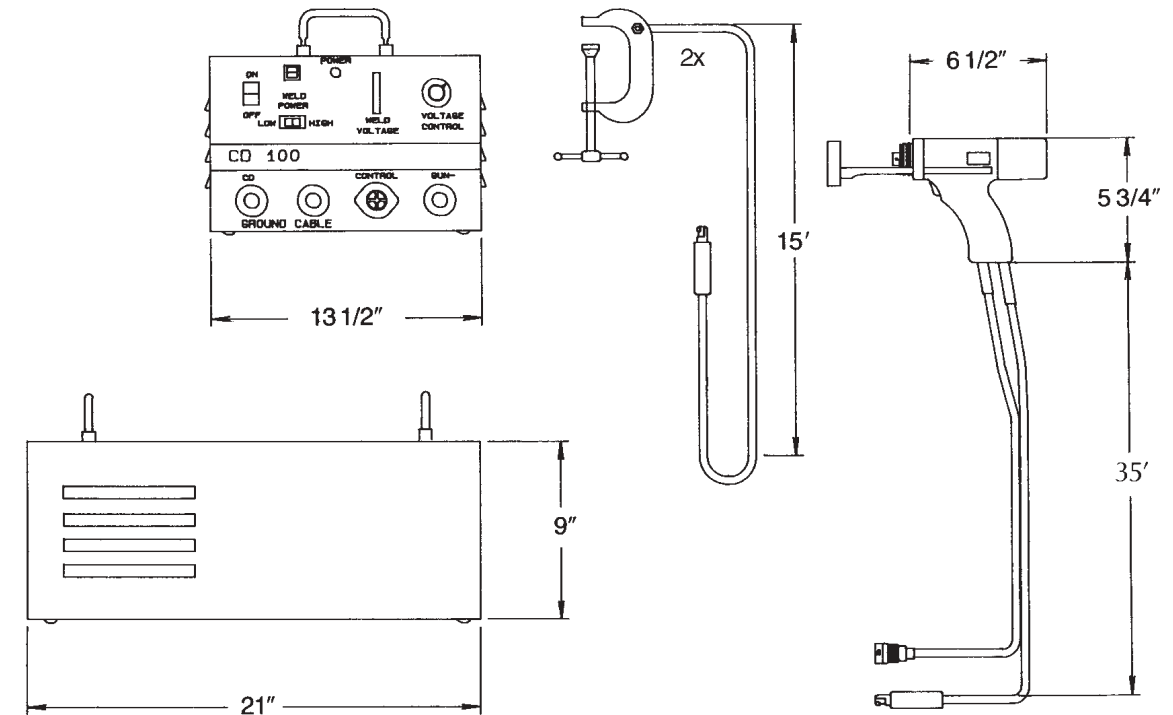

SPECIFICATIONS:

POWER SUPPLY/CONTROLLER

Height	9"
Width	13-1/2"
Depth	21"
Weight	66 Pounds
Capacitance	Low - 84,000 mfd High - 168,000 mfd
Weld Rate	up to 14/Min.
Weldable Materials	Mild Steel, Stainless Steel, Aluminium
Pin/Stud Range	14 Ga, thru 3/8" Dia. weld base
Weld Voltage	35-175 VDC
Weld Mode	Contact
Power Requirement	115VAC, 60 Hz, 30 Amp

WELD GUN (CD-2P PRECISION)

Weight	1-1/2 Lbs. (Not including cable)
Size (LWH)	6-1/2" x 2" x 5-3/4"
Weldable Dia.	14 Gauge through 3/8" Dia.
Material	High strength, impact resistance, polycarbonate

CABLES

Ground Cable	#1 x 15 Ft. (two each)
Gun Extension Set	#1 x 18/2 x 35 Ft. (direct to gun)



MIDWEST Fasteners, Inc.
 450 Richard St. • Miamisburg, OH 45342
 www.midwestfasteners.com • email: sales@midwestfasteners.com
 Toll Free: 800/852-8352 • Fax: 937/866-4174